

全长	螺纹部长	颈下长	柄部长	柄径	四角部宽	四角部长
L	ℓ	ℓ <sub>n</sub>	ℓ <sub>s</sub>	D <sub>s</sub>	K	ℓ <sub>k</sub>

# FC-HT

铸铁用直沟丝攻  
样式特长



■加工铸铁等硬且脆的材料时·丝攻磨损快·精度特别做加大设计。

被削材和推荐的攻牙速度

铸铁  
Cast irons  
**5~10**  
(m/min)

※详细图解说明请参阅P24

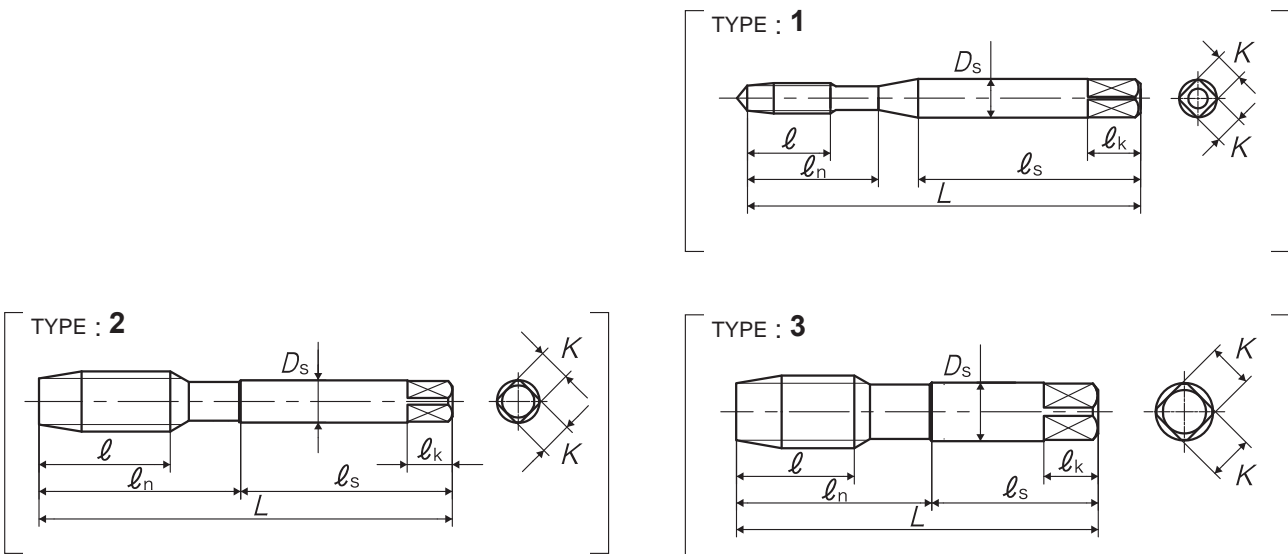

品区：1A

尺寸	等级	产品编号	吃入部	L (mm)	ℓ (mm)	ℓ <sub>n</sub> (mm)	ℓ <sub>s</sub> (mm)	D <sub>s</sub> (mm)	K (mm)	ℓ <sub>k</sub> (mm)	沟数	构型	库存
公制螺纹用													
<b>M3×0.5</b>	P3	TY3.0GRAEN5	5P	46	9	14	26	4	3.2	6	3	1	○
		TY3.0GRAENA	1.5P										
<b>M3.5×0.6</b>	P3	TY3.5HRAEN5	5P	52	11	16	29	5	4	7	3	1	△
		TY3.5HRAENA	1.5P										
<b>M4×0.7</b>	P3	TY4.0IRAEN5	5P	52	11	17	29	5	4	7	3	1	○
		TY4.0IRAENA	1.5P										
<b>M5×0.8</b>	P3	TY5.0KRAEN5	5P	60	13	22	33	5.5	4.5	7	3	1	○
		TY5.0KRAENA	1.5P										
<b>M6×1</b>	P3	TY6.0MRAEN5	5P	62	15	26	33	6	4.5	7	3	1	◎
		TY6.0MRAENA	1.5P										
<b>M8×1.25</b>	P3	TY8.0NRAEN5	5P	70	19	-	36	6.2	5	8	3	2	◎
		TY8.0NRAENA	1.5P										
<b>M8×1</b>	P3	TY8.0MRAEN5	5P	70	19	-	36	6.2	5	8	3	2	△
		TY8.0MRAENA	1.5P										
<b>M10×1.5</b>	P4	TY0100SAEN5	5P	75	23	-	38	7	5.5	8	4	2	◎
		TY0100SAENA	1.5P										

螺旋丝攻  
(盲孔用)

螺旋型  
先端丝攻  
(通孔用)

先端丝攻  
(通孔用)

直沟丝攻

超硬丝攻

挤压丝攻

特殊螺纹  
检查工具

管用丝攻

螺纹铣刀

圆板牙

中心钻

孔面工具

# 直沟丝攻系列

## FC-HT 铸铁用直沟丝攻

尺寸	等级	产品编号	吃入部	L (mm)	ℓ (mm)	ℓn (mm)	ℓs (mm)	Ds (mm)	K (mm)	ℓk (mm)	沟数	构型	库存
M10×1.25	P3	TY010NRAEN5	5P	75	23	-	38	7	5.5	8	4	2	◎
		TY010NRAENA	1.5P										○
M10×1	P3	TY010MRAEN5	5P	75	23	-	38	7	5.5	8	4	2	○
		TY010MRAENA	1.5P										○
M12×1.75	P4	TY012PSAEN5	5P	82	26	-	42	8.5	6.5	9	4	2	◎
		TY012PSAENA	1.5P										○
M12×1.5	P4	TY0120SAEN5	5P	82	26	-	42	8.5	6.5	9	4	2	○
		TY0120SAENA	1.5P										○
M12×1.25	P4	TY012NSAEN5	5P	82	26	-	42	8.5	6.5	9	4	2	○
		TY012NSAENA	1.5P										○
M12×1	P3	TY012MRAEN5	5P	82	26	-	42	8.5	6.5	9	4	2	△
		TY012MRAENA	1.5P										○
M14×2	P4	TY014QSAEN5	5P	88	26	-	45	10.5	8	11	4	2	○
		TY014QSAENA	1.5P										○
M14×1.5	P4	TY0140SAEN5	5P	88	26	-	45	10.5	8	11	4	2	○
		TY0140SAENA	1.5P										○
M16×2	P4	TY016QSAEN5	5P	95	26	-	48	12.5	10	13	4	2	○
		TY016QSAENA	1.5P										○
M16×1.5	P4	TY0160SAEN5	5P	95	26	-	48	12.5	10	13	4	2	○
		TY0160SAENA	1.5P										○
M18×2.5	P5	TY018RTAEN5	5P	100	33	-	51	14	11	14	4	2	○
		TY018RTAENA	1.5P										○
M18×1.5	P4	TY0180SAEN5	5P	100	33	-	51	14	11	14	4	2	○
		TY0180SAENA	1.5P										○
M20×2.5	P5	TY020RTAEN5	5P	105	33	-	50	15	12	15	4	3	○
		TY020RTAENA	1.5P										○
M20×1.5	P4	TY0200SAEN5	5P	105	33	-	50	15	12	15	4	3	○
		TY0200SAENA	1.5P										○
M22×2.5	P5	TY022RTAEN5	5P	115	33	-	55	17	13	16	4	3	△
		TY022RTAENA	1.5P										○
M22×1.5	P4	TY0220SAEN5	5P	115	33	-	55	17	13	16	4	3	△
		TY0220SAENA	1.5P										○
M24×3	P5	TY024STAEN5	5P	120	39	-	55	19	15	18	4	3	△
		TY024STAENA	1.5P										○
M24×1.5	P4	TY0240SAEN5	5P	120	39	-	55	19	15	18	4	3	○
		TY0240SAENA	1.5P										○

※「铸铁用直沟丝攻FC-0」,于2015年12月起停止生产。关于FC-0产品,请参阅「2013-2014年版综合型录」。

螺旋丝攻  
(盲孔用)

螺旋型  
(通孔用)

先端丝攻  
(通孔用)

直沟丝攻

超硬丝攻

挤压丝攻

特殊螺纹  
筒易检查工具

管用丝攻

螺纹铣刀

圆板牙

中心钻

孔面工具